

Yuasa Fiche de données techniques

Yuasa DCB890-8(ET) Pro-Spec Deep Cycle Battery

Spécifications

Tension nominale (V)	8
20-hr rate capacity to 1.75v per cell at 20°C (Ah)	190
Capacité à 75A (min)	90
Capacité à 25A (min)	340

Capacité à 5h selon la température

40°C	105%
30°C	100%
0°C	80%

Dimensions

Longueur (mm)	262
Largeur (mm)	181
Hauteur (mm)	245
Hauteur avec les bornes (mm)	276
Poids (kg)	31.6

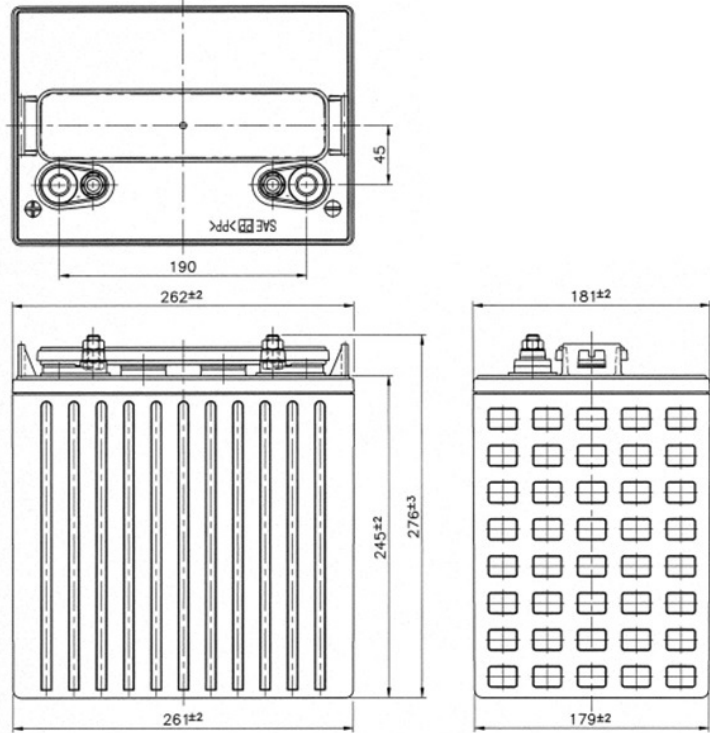

Spécifications sur le matériel

Type de capot	Amovible- maintenance possible
Type de capot à soupapes	: Gang style
Matière du bac et du couvercle	Plastique polypropylène noir
Méthode de soudage entre le bac et le couvercle	Thermosoudure
Type de connecteur inter-éléments	Soudure à travers la cloison
Méthode de soudure des plaques sur le strip inter-éléments	Processus automatisé cast-on
Matière de la plaque positive	Alliage plomb-antimoine
Matière de la plaque négative	Alliage plomb-antimoine

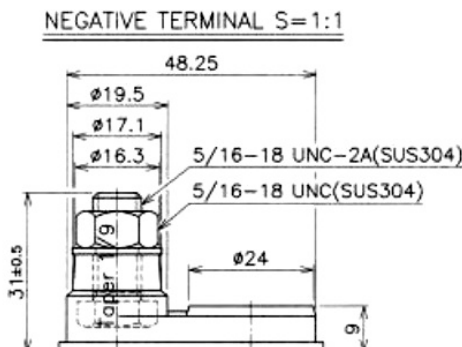
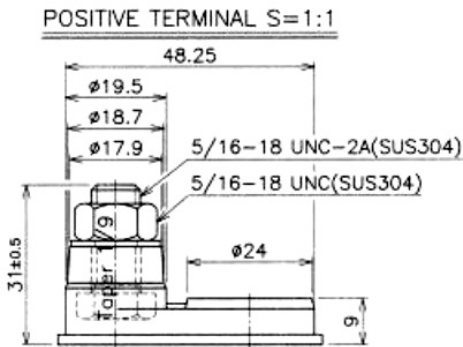

Date de publication: 22/03/2023 - E&OE

Yuasa Technical Data Sheet

Yuasa DCB890-8(ET) Pro-Spec Deep Cycle Battery

Specifications

Nominal voltage (V)	8
20-hr rate capacity to 1.75v per cell at 20°C (Ah)	190
Capacity @ 75A (mins)	90
Capacity @ 25A (mins)	340

5-Hr Capacity By Temperature

40°C	105%
30°C	100%
0°C	80%

Dimensions

Length (mm)	262
Width (mm)	181
Height (mm)	245
Height over terminals (mm)	276
Mass (kg)	31.6

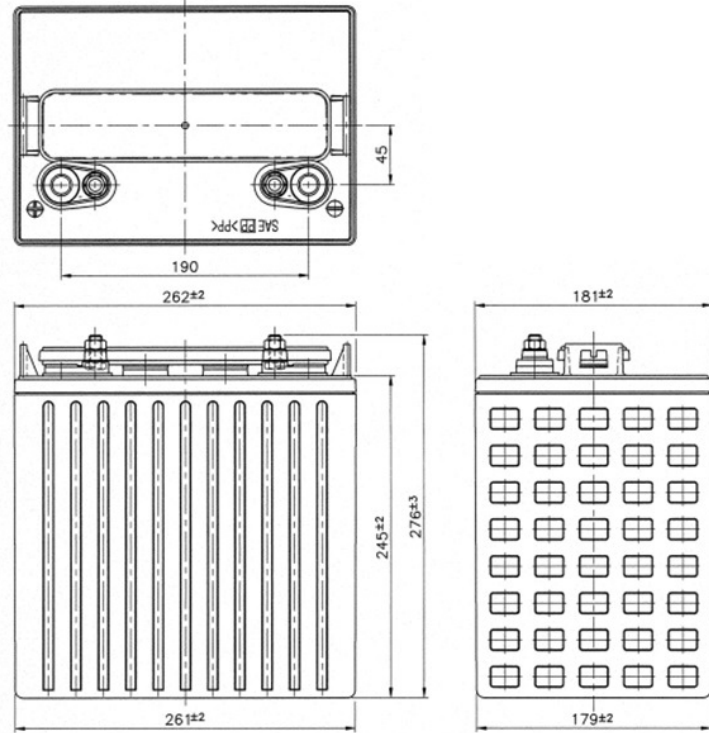

Material Specifications

Cover Style	: Removable - Maintenance Possible
Cover Vent Style	: Gang style
Container & Cover Material	: Black polypropylene plastic
Case to Cover Seal Method	: Heat sealing
Inner Cell Connector Type	: Through-partition weld
Plate Lug Weld Method	: Automated cast-on process
Positive Grid Material	: Antimony lead alloy
Negative Grid Material	: Antimony lead alloy

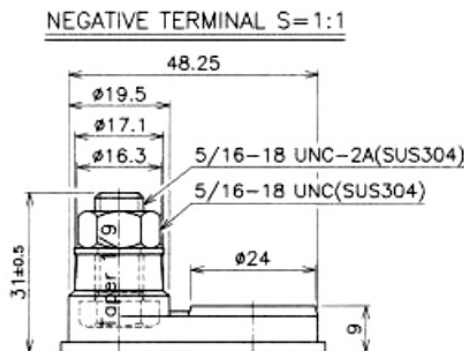
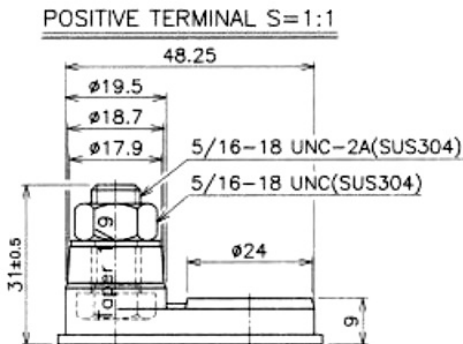

Data Sheet generated on 22/03/2023 - E&OE