

Yuasa Fiche de données techniques

Yuasa DCB145-6(ET) Pro-Spec Deep Cycle Battery

Spécifications

Tension nominale (V)	6
20hr rate Capacité en 20h à 260 10.5V/20°C (Ah)	
Capacité à 75A (min)	145
Capacité à 25A (min)	530

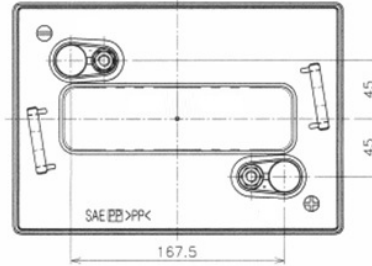

Capacité à 5h selon la température

40°C	105%
30°C	100%
0°C	80%

Dimensions

Longueur (mm)	259
Largeur (mm)	179
Hauteur (mm)	264
Hauteur avec les bornes (mm)	295
Poids (kg)	33

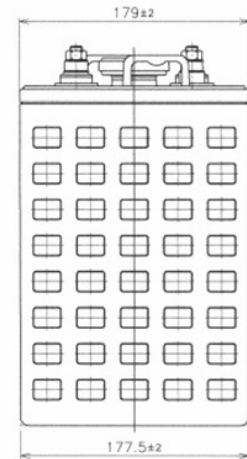
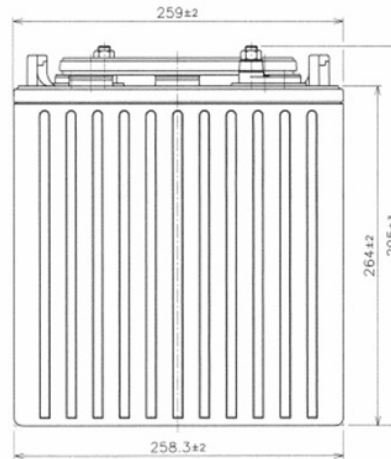

Spécifications sur le matériel

Type de capot	Amovible- maintenance possible
Type de capot à soupapes	: Gang style
Matière du bac et du couvercle	Plastique polypropylène noir
Méthode de soudage entre le bac et le couvercle	Thermosoudure
Type de connecteur inter-éléments	Soudure à travers la cloison
Méthode de soudure des plaques sur le strip inter-éléments	Processus automatisé cast-on
Matière de la plaque positive	Alliage plomb-antimoine
Matière de la plaque négative	Alliage plomb-antimoine

POSITIVE TERMINAL S=1:1

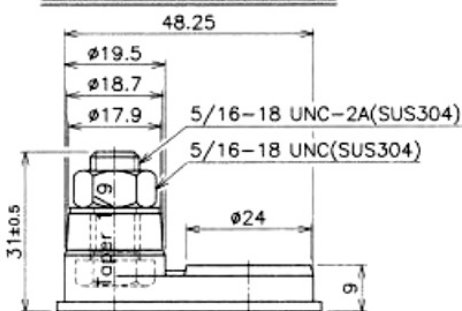

NEGATIVE TERMINAL S=1:1

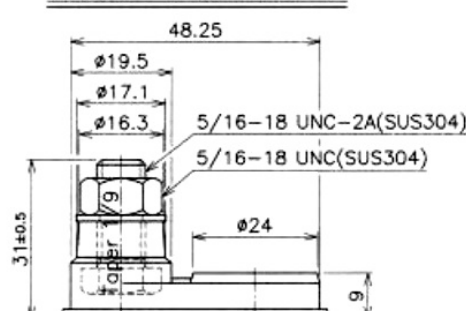

Date de publication: 31/01/2023 - E&OE

Yuasa Technical Data Sheet

Yuasa DCB145-6(ET) Pro-Spec Deep Cycle Battery



Specifications

Nominal voltage (V)	6
20-hr rate Capacity to 10.5V at 20°C (Ah)	260
Capacity @ 75A (mins)	145
Capacity @ 25A (mins)	530

5-Hr Capacity By Temperature

40°C	105%
30°C	100%
0°C	80%

Dimensions

Length (mm)	259
Width (mm)	179
Height (mm)	264
Height over terminals (mm)	295
Mass (kg)	33

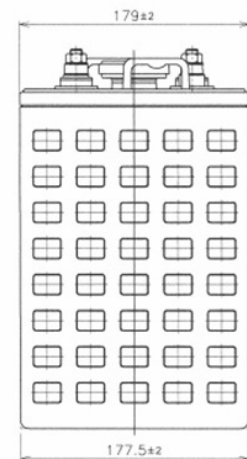
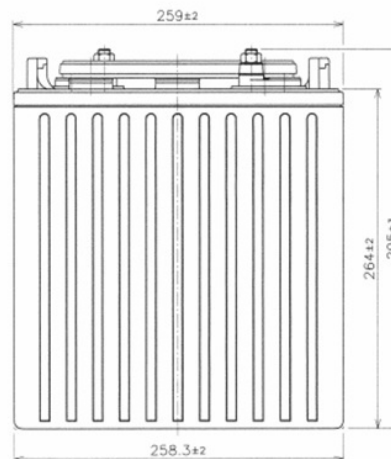
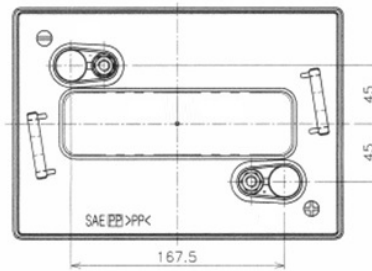

Material Specifications

Cover Style	: Removable - Maintenance Possible
Cover Vent Style	: Gang style
Container & Cover Material	: Black polypropylene plastic
Case to Cover Seal Method	: Heat sealing
Inner Cell Connector Type	: Through-partition weld
Plate Lug Weld Method	: Automated cast-on process
Positive Grid Material	: Antimony lead alloy
Negative Grid Material	: Antimony lead alloy