

Yuasa Fiche de données techniques

Yuasa DCB1275-12(ET) Pro-Spec Deep Cycle Battery

Spécifications

Tension nominale (V)	12
5-hr rate Capacity to 10.5V at 20°C (Ah)	125
20hr rate Capacité en 20h à 10.5V/20°C (Ah)	150
Capacité à 75A (min)	70
Capacité à 25A (min)	290

Capacité à 5h selon la température

40°C	105%
30°C	100%
0°C	80%

Dimensions

Longueur (mm)	329
Largeur (mm)	181
Hauteur (mm)	245
Hauteur avec les bornes (mm)	276
Poids (kg)	37.5

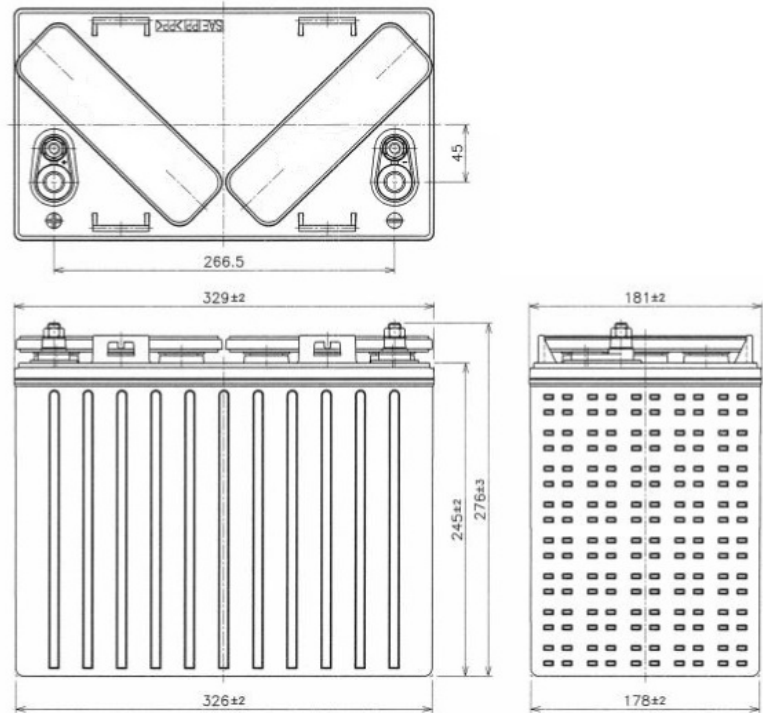

Spécifications sur le matériel

Type de capot	Amovible- maintenance possible
Type de capot à soupapes	: Gang style
Matière du bac et du couvercle	Plastique polypropylène noir
Méthode de soudage entre le bac et le couvercle	Thermosoudure
Type de connecteur inter-éléments	Soudure à travers la cloison
Méthode de soudure des plaques sur le strip inter-éléments	Processus automatisé cast-on
Matière de la plaque positive	Alliage plomb-antimoine
Matière de la plaque négative	Alliage plomb-antimoine

POSITIVE TERMINAL S=1:1

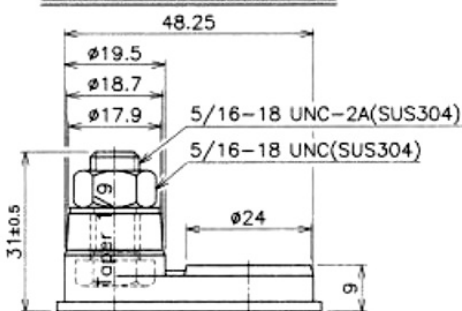

NEGATIVE TERMINAL S=1:1

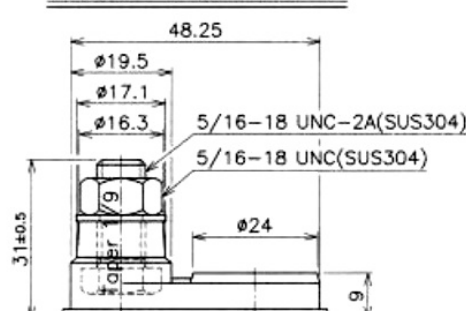

Date de publication: 15/04/2021 - E&OE

Yuasa Technical Data Sheet

Yuasa DCB1275-12(ET) Pro-Spec Deep Cycle Battery

Specifications

Nominal voltage (V)	12
5-hr rate Capacity to 10.5V at 20°C (Ah)	125
20-hr rate Capacity to 10.5V at 20°C (Ah)	150
Capacity @ 75A (mins)	70
Capacity @ 25A (mins)	290

5-Hr Capacity By Temperature

40°C	105%
30°C	100%
0°C	80%

Dimensions

Length (mm)	329
Width (mm)	181
Height (mm)	245
Height over terminals (mm)	276
Mass (kg)	37.5

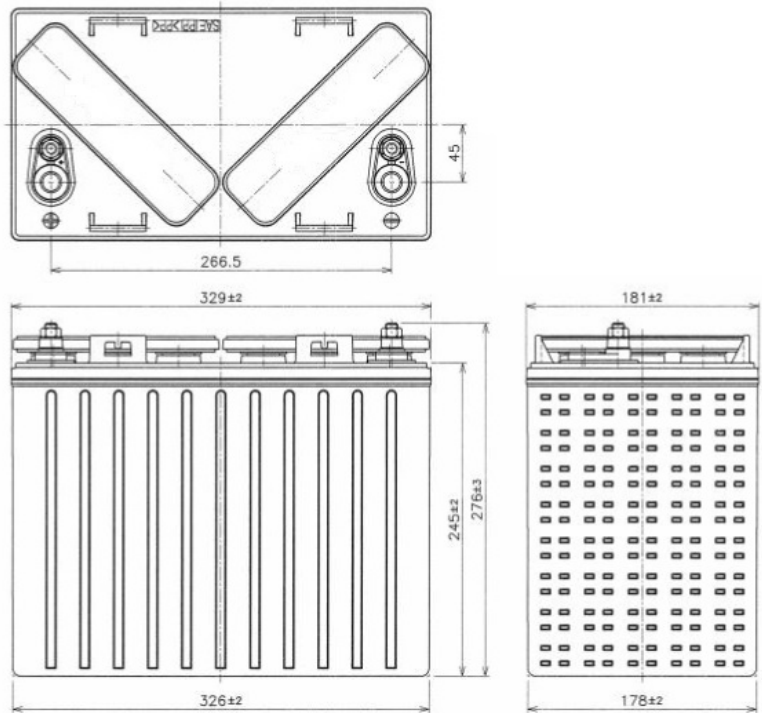

Material Specifications

Cover Style	: Removable - Maintenance Possible
Cover Vent Style	: Gang style
Container & Cover Material	: Black polypropylene plastic
Case to Cover Seal Method	: Heat sealing
Inner Cell Connector Type	: Through-partition weld
Plate Lug Weld Method	: Automated cast-on process
Positive Grid Material	: Antimony lead alloy
Negative Grid Material	: Antimony lead alloy

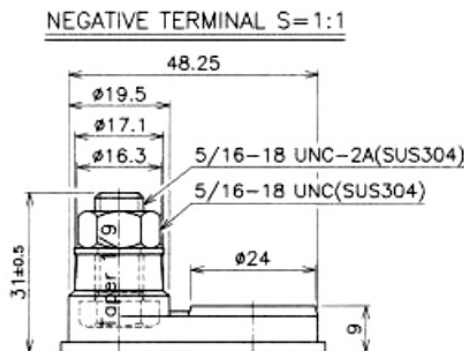
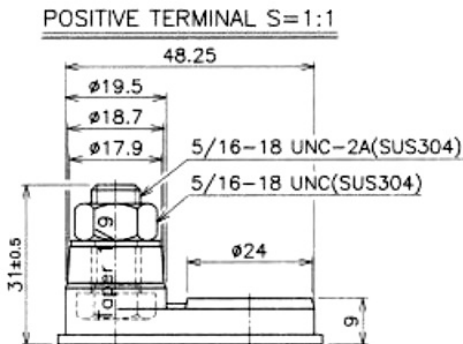

Data Sheet generated on 15/04/2021 - E&OE